	1	Date : 15/12/2022
		Page : 1 / 19

# PACKAGING HANDBOOK FOR THE SADEVGROUP'S SUPPLIERS

## SPECIFICATION FOR THE PACKAGING OF THE PARTS



<i>Applicant</i>	<i>Container (logistic)</i>	<i>Direction aimed</i>

<b>1.</b>	<b>FOREWORD</b>	<b>4</b>
<b>2.</b>	<b>SCOPE OF APPLICATION</b>	<b>5</b>
<b>3.</b>	<b>ACCEPTANCE BY THE SUPPLIER</b>	<b>6</b>
<b>4.</b>	<b>PACKING REQUIREMENTS</b>	<b>7</b>
<b>4.1.</b>	<b>Cardboard boxes requirements</b>	<b>7</b>
4.1.1.	Interior packing	8
4.1.2.	Parts protection:	10
4.1.3.	Package closure	11
<b>4.2.</b>	<b>Labelling of the cardboards</b>	<b>12</b>
4.2.1.	Size of the label	13
4.2.2.	Colour of the labels	13
4.2.3.	Position of the label	13
<b>4.3.</b>	<b>Palletisation</b>	<b>15</b>
4.3.1.	Pallets	15
4.3.2.	Dimension and weight of the loading	15
4.3.3.	Load stability	16
4.3.4.	Structure of unit load	16
<b>4.4.</b>	<b>Documents attached to the deliveries</b>	<b>17</b>
	<b>RETURN RECEIPT:</b>	<b>18</b>

## 1. Foreword

This manual was designed in collaboration with the partners of SADEVGROUPE. The goal is to give our partners a guideline of the packing required by SADEVGROUPE and to give assistance to standardise the packing.

The following packing requirements described below, were conceived to ensure that the products are delivered to the right place, at the right time, in the right quantity and without damages between the suppliers/shipper/ customers.

SADEVGROUPE recommends that the department- responsible for packing, transport and shipment know the ins and outs of this manual.

SADEVGROUPE's suppliers are responsible for the packing.

Should you have any queries, please do not hesitate to contact the following:

SADEVGROUPE  
2 allée des Faisans  
Z.I. de Vovray - SEYNOD  
F-74600 ANNECY  
France

Logistic department  
M. Daniel PEREZ  
Tel: +33 (0)4.50.33.70.61  
Email : [logistique@saddevgroup.com](mailto:logistique@saddevgroup.com)

## **2. Scope of application**

These guidelines shall apply to all production parts and to all suppliers of SADEVGROUP. These specifications replace all the former guidelines of packing, except for specific cases.

In the absence of specific conditions applying to specific parts, these guidelines are the reference frame.

Packing and conditioning must be designed in order to ensure that the parts will be delivered without damages. Damaged packing leads to believe that the products are defective, and consequently will not be accepted by SADEVGROUP or by its partners.

The suppliers must notify SADEVGROUP at the price quotation and before the delivery, if they can not deliver the parts in compliance with these conditions.

Any other packing must be validated by SADEVGROUP. Suppliers must submit a packaging proposal to SADEVGROUP for approval. Without this approval, SADEVGROUP will refuse the delivery, at the risk and the expense of the supplier.

Failure to enforce these specifications will involve refusal of the delivery and/or extra fees (extra workforce costs for the sorting, the repackaging...).

### **3. Acceptance by the supplier**

All new suppliers of SADEVGROUP shall acquaint itself with these requirements before any first order.

Please print the return receipt, page 17, and return it properly signed so as to confirm the reading of this manual and the acceptance of the respect of its content and its requirements.

This guideline can be updated by SADEVGROUP. To check the validity of this document or to obtain the last version, log on to the web site of SADEVGROUP [www.sadegroup.com](http://www.sadegroup.com), or contact Mr. BOISVERT.

## 4. Packing requirements

### 4.1. Cardboard boxes requirements

- The cardboard box, uses for packing, is the standard box for turned parts with double wall corrugated quality.
- Simple wall corrugated quality is prohibited.
- The standard cardboards with lids shall be used only for palletized shipment.
- The dimensions of the cardboard boxes shall correspond the most to the ones described below:

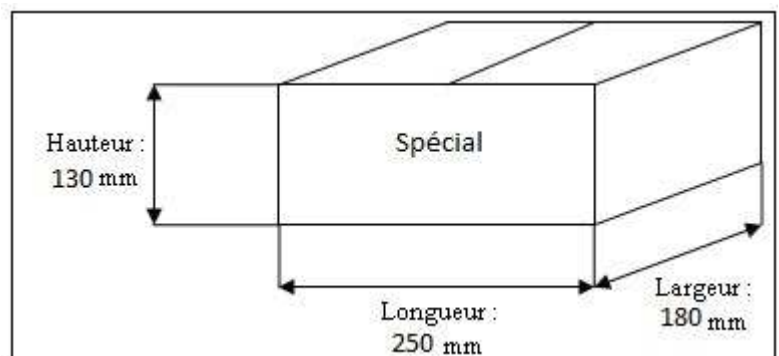
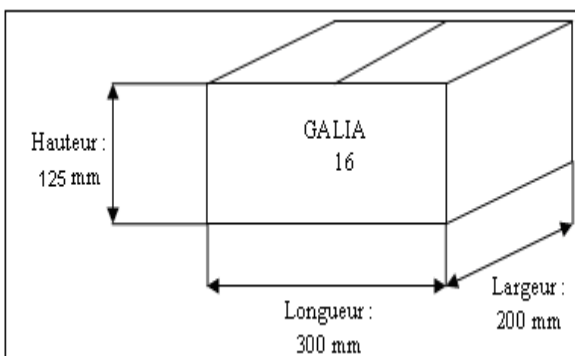
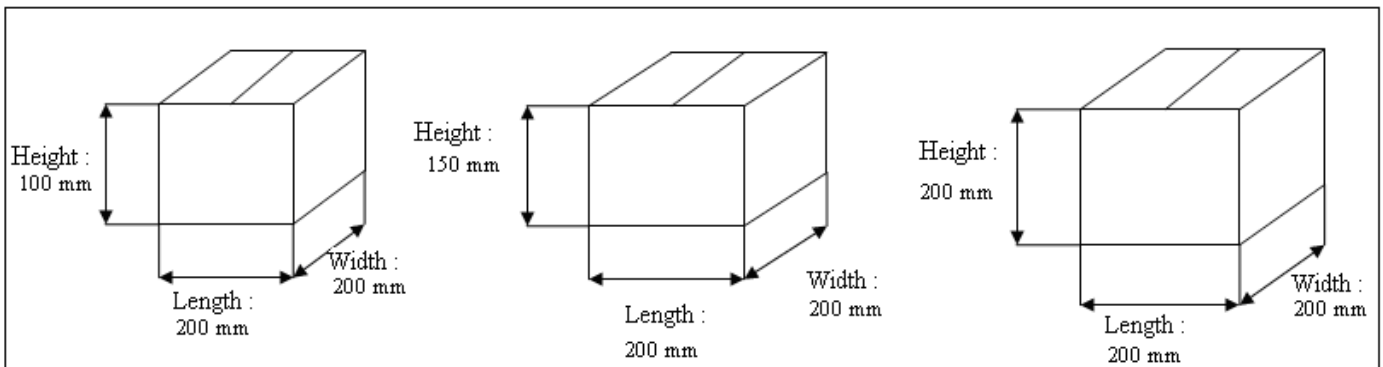

- The gross weight per cardboard box requested is **8kg**.  
The gross weight per cardboard box should not exceed **10 kg**.
- The size of the cardboard boxes must be adapted to the contents in order to be filled at the maximum of its capacity within the limit of the maximum weight.
- The deliveries in bags or in plastic storage boxes are prohibited.



- Each cardboard box must include only one reference of parts. Any cardboard box containing several references will be refused and returned.
- **Note concerning the long parts (superior to 250 mm):**

These parts must be delivered either tied up together with resistant bonds (metallic or plastic) or in tubes. Tying up the parts with adhesive tape is forbidden. The weight of each tube shall not exceed 8 kg.

#### 4.1.1. Interior packing

- Parts in bulk must be packed in **polythene bags**.



- The size of the bags is adapted to the content<sup>1</sup>, closed with a nylon cable ties or others (plastic twist ties, metal wire sack ties), to prevent that the content do not spill out during transport.

<sup>1</sup> I.e. according to the typology of the parts.

- Staples to close the bags are tolerated but their number must be limited.
- The large size polythene bags must be fold up (in order to avoid the spreading of the parts) but it would be preferable to close the bags with ties.









- The bags shall neither be welded nor sealed.
- Plastic zip bags are prohibited.
- For the medium- or large-size parts, the suppliers have to adapt the standard of packing to the typology of the product (tolerance, sharp edge, quality surface ...).
- Unless otherwise specified, all the crude steel parts must be delivered slightly lubricated to avoid corrosion during the storage.

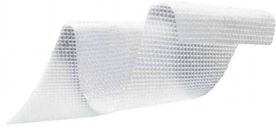

4.1.2. Parts protection:

- The cardboard box must resist to the crushing due to its palletisation.
- Any void spaces must be filled with cushioning materials.

<u>Cushioning materials requested</u>	<u>Cushioning materials prohibited</u>
<p>- Recycled Cardboard boxes</p> 	<p>- Newspapers</p>
<p>V - Kraft paper</p> 	<p>- Recycled Paper</p>
<p>- Bubble Wrap</p> 	<p>- Flo pack</p> 
	<p>- Foam</p> 
	<p>- Polystyrene</p> 



Example of acceptable cushioning material



Example of prohibited cushioning material

- The heavy parts must be well-arranged and fixed. Each layer of parts must be separated by corrugated pads to avoid the frictions and the shocks during the transport. Using sheets of paper between each layer is forbidden.



The parts are neither well-arranged nor fixed with pads

#### 4.1.3. Package closure

- The cardboard box must be correctly closed with transparent and neutral adhesive tape.
- The bottom of the cardboard box must be closed with two crossed strips of adhesive tape.
- The adhesive tape must be stuck over the entire length of the cardboard box. If the cardboard box contains heavy parts, the adhesive tape must be doubled.

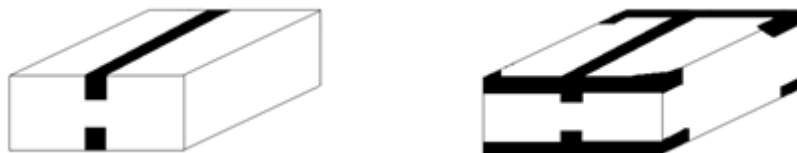

Acceptable package closure

- Box closure shall permit access to the contents without destroying the usefulness of the package.
- The adhesive tape shall not be used in an exaggerated way.



Improper use of adhesive tape

- **Staples are prohibited.** They can be tolerated only to *close the bottom of the cardboard box*. Their numbers are limited to three.
- Strapping is allowed.
- Cardboard boxes with lids must be closed with straps or adhesive tape like the model below: two straps minimum.

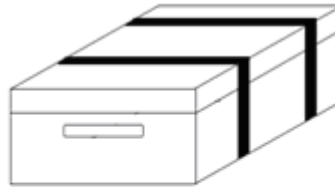

Acceptable closure for cardboard boxes with lids

#### **4.2. Labelling of the cardboards**

- Each cardboard box must carry a label. Labelling must be quite readable and resist to the usual conditions of transport.
- The labels must be completed on a computer through SADEVGROUP web site. The labels must be printed with a standard printer on label sheets.
- Log on to your personal space through the following link : [http://www.sadevgroup.com/sadev\\_commande/fournisseur/index.php](http://www.sadevgroup.com/sadev_commande/fournisseur/index.php)
- The labels must be **NEUTRAL**, i.e. they shall neither mention brands nor logos, address, telephone, web site relating to the suppliers.

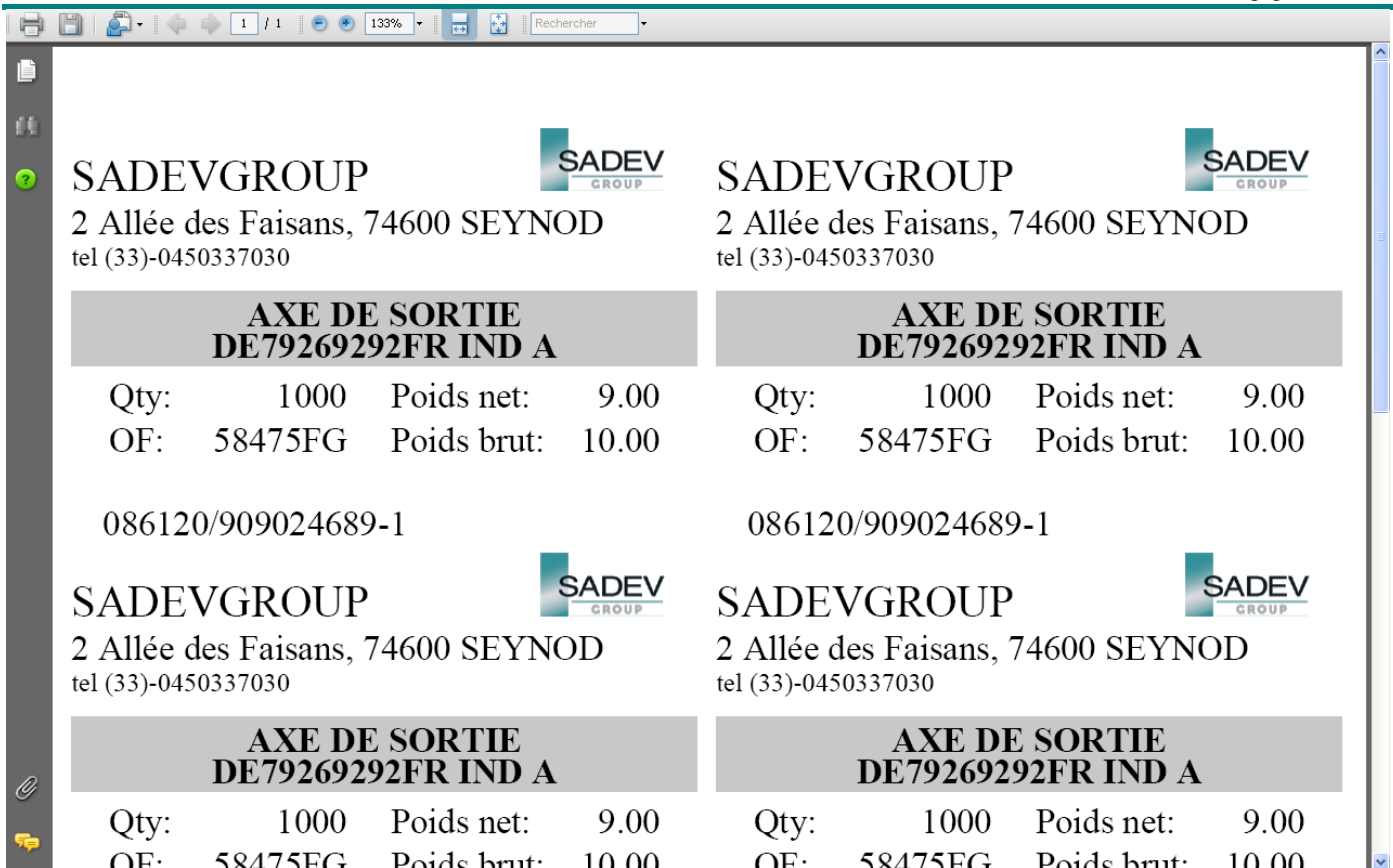

Example of the Label SADEV

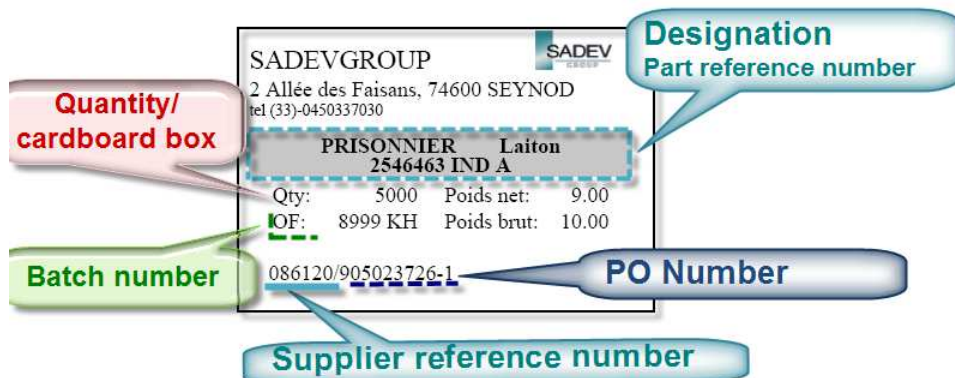

4.2.1. Size of the label

- Dimensions of one label are (L X l): 99.1 X 67.7mm. Each sheet of labels includes 8 labels.

4.2.2. Colour of the labels

- The labels are printed on a white background with black ink.

4.2.3. Position of the label

- Each cardboard box shall have only one label.

- For the standard cardboard boxes the label is placed on the top of the cardboard, in the top left corner.



**Acceptable position of the label**



**Prohibited position**

- For cardboard box with lid the label is placed in the centre of the lid, like the model below :



**Position of the label on a cardboard box with lid**



**Prohibited position**

- Labels inside the cardboard boxes are prohibited.
- The label shall not be hidden by the adhesive tape or the strap.
- The label shall not be stuck on the adhesive tape or on the strap.

**4.3. Palletisation**

- SADEVGROUP accepts the deliveries either in separate cardboard box or in pallet.
- Beyond 5 cardboard boxes or when the number of cardboard boxes is sufficient to form a layer, the palletisation is wished.

4.3.1. Pallets

Requested	Refused
<ul style="list-style-type: none"> <li>- 1/2 Pallet with rafters (L X I) 800 X 600 mm.</li> <li>- EUR Pallet (L X I): 1200 X 800 mm</li> </ul>	<ul style="list-style-type: none"> <li>- Carton pallet</li> <li>- Plastic pallet</li> </ul>



**EUR Pallet**



**1/2 Pallet**

4.3.2. Dimension and weight of the loading

- For the half pallet: the acceptable gross weight of a load unit is max. **200 kg**.
- For the Eur. pallet: the acceptable gross weight of a load unit is max. **600 kg**.

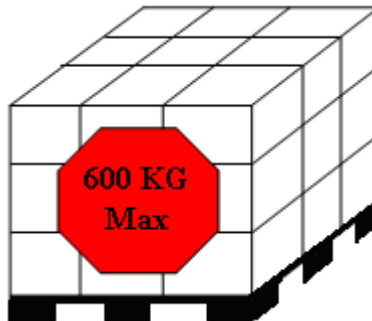

#### 4.3.3. Load stability

- All package shipped on the pallets must be adequately secured to the pallets.
- Packages must be stretch wrapped to the pallet for load consolidation with plastic strapping, stretchable or retractable film.



- The use of metal strapping, staples or ropes to maintain the load are prohibited.

#### 4.3.4. Structure of unit load

- Overhanging or misaligned of the loads are not allowed. The cardboard boxes shall be placed by the book.
- Brick and pyramid stacking are not allowed.
- The first rank is formed by the heaviest cardboard boxes.
- All packages must have sufficient strength and stability to withstand double stacking of the pallet load.

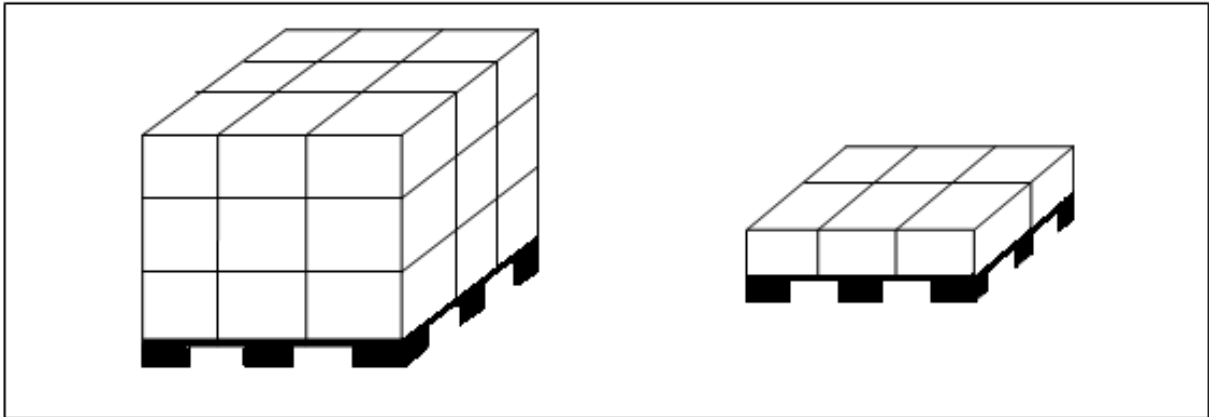

Example of acceptable stacking

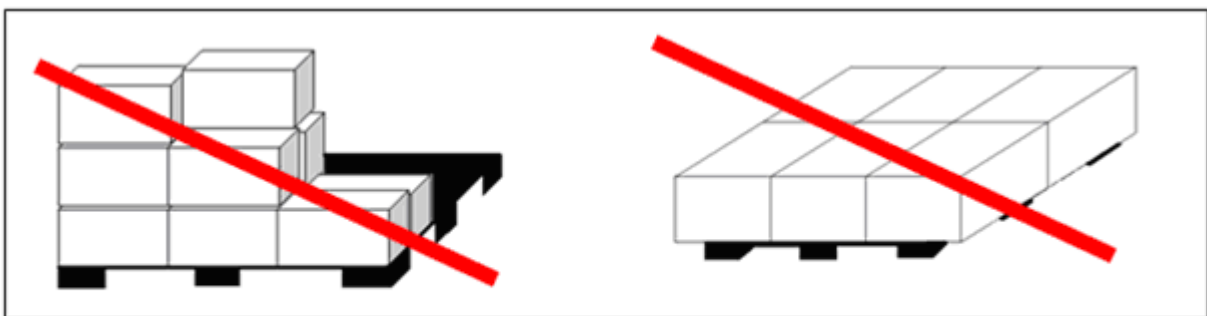

No pyramid shaped loads

Overhanging is forbidden

**Note:** If the number of cardboard boxes is not sufficient to form a complete layer it is appropriate to add empty cardboard boxes so as to fill out the layer and assure stability.

#### **4.4. Documents attached to the deliveries**

- The documents joined with the shipment (packing list, various certificates required) must be placed in a “Document enclosed” envelope”. This one shall be stuck on the side of the cardboard box set above the batch. The envelope shall not hide the label.
- The documents shall not be placed inside the cardboard boxes.

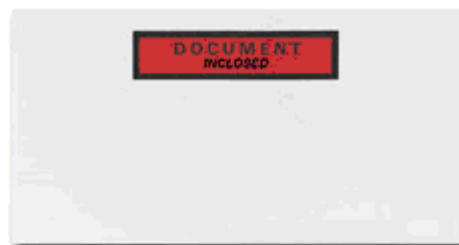



---

**Return receipt:**

As a representative of \_\_\_\_\_, by the present one I acknowledge receipt of the handbook of the procedures packing SADEVGROUPE. I certify to have read and understood the content and I agree to comply with the specifications before-mentioned.

Information of the person in charge of the packing/shipment in the company:

NAME: \_\_\_\_\_

DATE: \_\_\_\_\_

SIGNATURE:

Please return this document to SADEVGROUPE to the attention of Daniel PEREZ. The absence of answer does not release from the conditions written in this handbook.

Appendix

	appendix  Packing instructions D98-00	
<b>Dimensions</b>		
<ul style="list-style-type: none"> <li>- L. 200 x l. 200 x H. 100 DW</li> <li>- L. 200 x l. 200 x H. 150 DW</li> <li>- L. 200 x l. 200 x H. 200 DW</li> <li>- <b>GALIA 16</b>: L. 300 x l. 200 x H. 125</li> </ul>		
<b>Weight</b>		
<b>8 KG/</b> Cardboard box required- <b>10 KG max/</b> Cardboard box permitted -1 Reference/Cardboard box		
<b>Interior</b>		
<ul style="list-style-type: none"> <li>-1 Reference/Cardboard box</li> <li>- Parts in bulk in polythene bags, size adapted to the contents</li> <li>- Closed with twist ties, drill binder, or staples</li> <li>- Crude Steel Parts slightly lubricated</li> </ul>		
<b>Parts protection</b>		
<ul style="list-style-type: none"> <li>- Fill the package, fill the void space</li> <li>- Void fillers : cardboard box recycled with cardboard shredder, kraft paper, bubble wrap</li> <li>-Use of corrugated pads for heavy parts</li> </ul>		
<b>Cardboard box closure</b>		
<ul style="list-style-type: none"> <li>- Clear and neutral adhesive tape</li> <li>- <b>Staples prohibited</b>, 3 staples allowed to close the bottom of the cardboard box</li> <li>- Strapping permitted</li> </ul>		
<b>Labelling</b>		
<ul style="list-style-type: none"> <li>- <b>NEUTRAL</b> Labels</li> <li>- Dimension : 99.1 X 67.7 mm</li> <li>- 1 label per cardboard box</li> <li>- No label inside the cardboard box</li> </ul>		
<b>Enclosed documents</b>		
<ul style="list-style-type: none"> <li>- Documents placed in «document enclosed » envelope.</li> <li>- Envelope stuck on the cardboard box's sides, placed at the top of the batch.</li> <li>- No document inside the package</li> </ul>		
<b>Palletization</b>		
<ul style="list-style-type: none"> <li>- Half-pallet : maximum weight 300 kg</li> <li>- Euro pallet : maximum weight 600 kg</li> <li>- Pallet maintained with stretch film / strapping</li> </ul>		